

A collection of frozen drinks and an ice cream cone on a marble surface. In the foreground, a waffle cone with white ice cream and colorful sprinkles sits on a metal spring stand. To its right is a glass of orange slush with a cherry on top. Behind it is a glass of chocolate milkshake with whipped cream and a nut. Further back is a tall glass of red slush with strawberries and a red straw. To the left, a margarita with a lime wedge and a glass of white wine are visible. The background is a soft green wall.

pampered|chef.

FreezyFun Ultimate Frozen Drink & Soft-Serve Maker

START GUIDE

Get to Know Your FreezyFun Ultimate Frozen Drink & Soft-Serve Maker

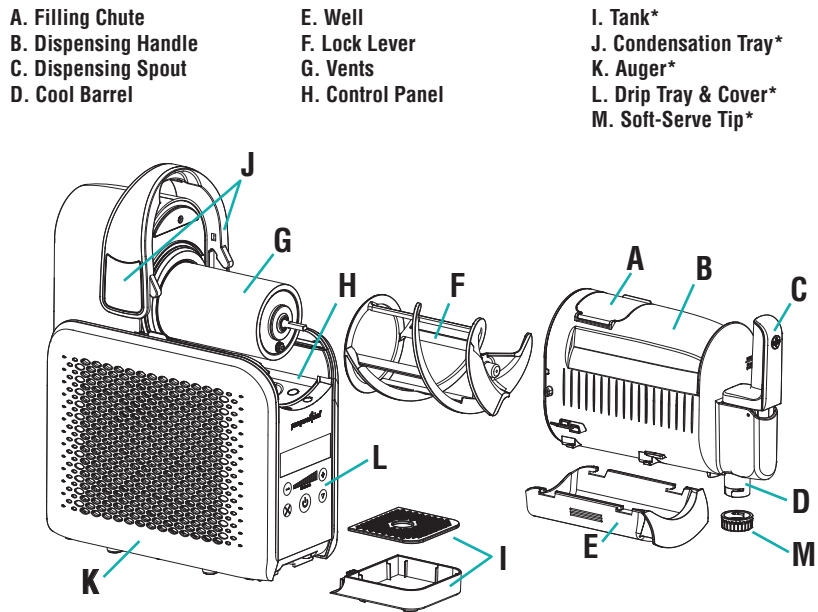

*These parts are dishwasher-safe.

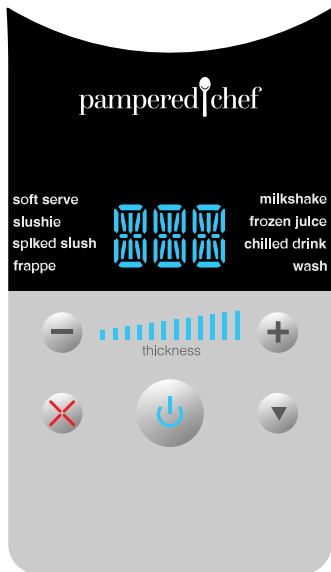

Using the Control Panel

Power Button
Press to turn the appliance on. Press and hold to turn the appliance off.

Presets
Choose from a selection of presets to achieve the ideal temperature and thickness for your frozen creations. Refer to the chart on p. 3.

Wash Preset
Use this cycle to rinse the appliance. Refer to the back cover for more details.

Customize Thickness
Press the minus button to decrease the thickness and the plus button to increase the thickness of your frozen drink.

Cancel Button
Press any time to cancel functions. The screen will default to the Wash preset.

Arrow Button
Press to cycle through the different presets.

Picking Your Presets

From slushies to soft serve, there's a preset for every cool craving.

| Preset | Default Thickness | Thickness Adjustment Based on Environment Temperature* | Ideal Capacity | Cool Creations |
|---------------|-------------------|--|------------------------------|---|
| Soft Serve | 12 bars | 5 bars | 30 fl. oz. (875 mL)** | Make soft and airy ice cream. |
| Slushie | 6 bars | 1 bar | 16–64 fl. oz. (500 mL–1.9 L) | Turn soda and other everyday beverages into sweet treats. |
| Spiked Slush | 8 bars | 1 bar | 16–64 fl. oz. (500 mL–1.9 L) | Create frozen cocktails at home. |
| Frappe | 4 bars | 1 bar | 16–64 oz. (500 mL–1.9 L) | Whip up frozen coffee drinks whenever you want. |
| Milkshake | 4 bars | 1 bar | 16–64 fl. oz. (500 mL–1.9 L) | Stir up thick milkshakes and other frosty treats. |
| Frozen Juice | 6 bars | 1 bar | 16–64 fl. oz. (500 mL–1.9 L) | Turn any kind of juice into a frosty drink with sweet, fruity flavor. |
| Chilled Drink | 1 bar | 1 bar | 16–64 fl. oz. (500 mL–1.9 L) | Stay refreshed with perfectly chilled drinks. |
| Wash | — | — | 64 fl. oz. (1.9 L) | Easily wash the appliance as soon as you're done using it. |

*Room temperature can affect your machine's output. Start at a lower thickness (see chart) and increase gradually to prevent your treat from over-freezing.
If the machine stops:
1. Press Cancel and wait 10–15 minutes.
2. Select your preset and start at the lower thickness, increasing to your liking.
3. Let it run until you're ready to dispense.

While some mixes exceed the 30 fl. oz. (875-mL) limit for the Soft Serve preset like the **FreezyFun Pineapple Mix (sold separately), those mixes are specially formulated to be used with this machine.

Important Info

- Mix all your ingredients together continuously for 2–3 minutes, or until the sugar has completely dissolved.
- You can adjust the thickness setting at any time while the machine is running.
- Dispense at least 1 cup (250 mL) early and often to keep your mixture smooth and the filling chute clear.

Sugar Guidelines

Sugar is an important component because it lowers the freezing point of liquids, helping them slush rather than freeze. When there's too much or not enough sugar, your chosen drink won't slush.

Use this rule: For every 8 ounces (250 mL) of liquid, you'll need at least 8 grams of sugar.



Diet sodas and sugar-free drinks don't work with this machine. Because they're made with artificial sweeteners, they lack the necessary sugar to create a smooth, consistent slush.

For best results, **use drinks that contain at least 4% sugar**. And if you want to use a sugar substitute, use allulose. It behaves a lot like real sugar when freezing.

Hard Alcohol & Spirit Guidelines

Use the Spiked Slush preset whenever you're adding hard alcohol or spirits to your mixture.

All alcoholic beverages (wine, beer, seltzer, etc.) must contain 2.8–16% alcohol.

| Total Serving Size | Maximum Alcohol Amount |
|---------------------|------------------------|
| 16 fl. oz. (500 mL) | 2.5 fl. oz. (75 mL) |
| 32 fl. oz. (1 L) | 5 fl. oz. (175 mL) |
| 64 fl. oz. (1.9 L) | 10 fl. oz. (400 mL) |

Adding too much alcohol to your mixture can prevent it from freezing. Refer to the chart above when using hard alcohol or spirits (35%+).

One-Ingredient Wins

Turn an ingredient you already know and love into a creamy, dreamy frozen delight.

Pour your ingredient into the **running machine**.

| Ingredients | Preset | 2 Servings | 4 Servings | 8 Servings |
|--|---------------|-----------------|--------------|------------------|
| Eggnog | Soft Serve | — | — | 3¾ cups (875 mL) |
| Sweetened (regular) soda | Slushie | 2 cups (500 mL) | 4 cups (1 L) | 8 cups (1.9 L) |
| Lemonade or limeade | Slushie | 2 cups (500 mL) | 4 cups (1 L) | 8 cups (1.9 L) |
| Fruit punch | Slushie | 2 cups (500 mL) | 4 cups (1 L) | 8 cups (1.9 L) |
| Sweetened iced tea | Slushie | 2 cups (500 mL) | 4 cups (1 L) | 8 cups (1.9 L) |
| Sweetened sports or energy drink | Slushie | 2 cups (500 mL) | 4 cups (1 L) | 8 cups (1.9 L) |
| Prepared cocktail mixture | Spiked Slush | 2 cups (500 mL) | 4 cups (1 L) | 8 cups (1.9 L) |
| Store-bought iced coffee with milk and sugar | Frappe | 2 cups (500 mL) | 4 cups (1 L) | 8 cups (1.9 L) |
| Chocolate milk | Milkshake | 2 cups (500 mL) | 4 cups (1 L) | 8 cups (1.9 L) |
| Fruit juice | Frozen Juice | 2 cups (500 mL) | 4 cups (1 L) | 8 cups (1.9 L) |
| White wine or rosé | Chilled Drink | 2 cups (500 mL) | 4 cups (1 L) | 8 cups (1.9 L) |





Two-Ingredient Twists

Mix two of your favorite beverages to create frozen sips that'll wow every taste bud in 15–60 minutes.

Whisk your ingredients in a large bowl with a spout until fully combined **before adding to the running machine**.

| Frozen Drink | Ingredients | 2 Servings | 4 Servings | 8 Servings |
|----------------------------------|------------------------------|---------------------|--------------------|---------------------|
| Slushie | | | | |
| Ocean breeze | Blue sports drink | 1½ cups (375 mL) | 3 cups (725 mL) | 6 cups (1.4 L) |
| | Coconut milk | ½ cup (125 mL) | 1 cup (250 mL) | 2 cups (500 mL) |
| Cherry cola | Cola | 1¾ cups (425 mL) | 3½ cups (825 mL) | 7 cups (1.75 L) |
| | Maraschino cherry juice | ¼ cup (60 mL) | ½ cup (125 mL) | 1 cup (250 mL) |
| Frosted orange juice or lemonade | Orange juice or lemonade | 1½ cups (375 mL) | 3 cups (725 mL) | 6 cups (1.4 L) |
| | Vanilla coffee creamer | ½ cup (125 mL) | 1 cup (250 mL) | 2 cups (500 mL) |
| Watermelon lime slush | Limeade | 1½ cups (375 mL) | 3 cups (725 mL) | 6 cups (1.4 L) |
| | Cubed and blended watermelon | ½ cup (125 mL) | 1 cup (250 mL) | 2 cups (500 mL) |
| Frozen Shirley Temple | Lemon-lime soda | 2 cups (500 mL) | 3¾ cups (875 mL) | 7¾ cups (1.8 L) |
| | Grenadine syrup | 2 tbsp (30 mL) | 3 tbsp (45 mL) | ¼ cup (60 mL) |
| Spiked Slush | | | | |
| Easy frozen margarita | Limeade | 1½ cups (400 mL) | 2½ cups (575 mL) | 4½ cups (1.1 L) |
| | Tequila | 2.5 fl. oz. (75 mL) | 5 fl. oz. (150 mL) | 10 fl. oz. (300 mL) |
| Frosé | Rosé wine | 1½ cups (375 mL) | 3 cups (725 mL) | 6 cups (1.4 L) |
| | White cranberry juice | ½ cup (125 mL) | 1 cup (250 mL) | 2 cups (500 mL) |
| Frozen vodka cranberry | Cranberry juice | 1¾ cups (400 mL) | 2½ cups (575 mL) | 4½ cups (1.1 L) |
| | Vodka | 2.5 fl. oz. (75 mL) | 5 fl. oz. (150 mL) | 10 fl. oz. (300 mL) |
| Frozen whiskey & cola | Cola | 1¾ cups (400 mL) | 2½ cups (575 mL) | 4½ cups (1.1 L) |
| | Whiskey | 2.5 fl. oz. (75 mL) | 5 fl. oz. (150 mL) | 10 fl. oz. (300 mL) |
| Frozen paloma | Grapefruit soda | 1¾ cups (400 mL) | 2½ cups (575 mL) | 4½ cups (1.1 L) |
| | Tequila | 2.5 fl. oz. (75 mL) | 5 fl. oz. (150 mL) | 10 fl. oz. (300 mL) |
| Frozen mimosa | Champagne | 1 cup (250 mL) | 2 cups (500 mL) | 4 cups (1 L) |
| | Orange juice | 1 cup (250 mL) | 2 cups (500 mL) | 4 cups (1 L) |
| Frozen Juice | | | | |

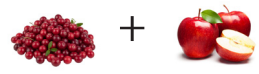
Combine equal amounts of both juices to create a perfectly balanced frozen drink.

| | | | |
|--|--|----------------------------------|--|
| Minimum capacity: 2 cups (500 mL) | | Maximum capacity: 8 cups (1.9 L) | |
| <p>Orange pineapple</p>  <p>Orange juice + Pineapple juice</p> | <p>Cranberry apple</p>  <p>Cranberry juice + Apple juice</p> | | |
| <p>Sunshine slush</p>  <p>Mango juice + Carrot juice</p> | <p>Virgin piña colada</p>  <p>Pineapple juice + Coconut milk</p> | | |

FreezyFun Soft Serve

soft serve

Yield
8–10 servings

Prep Time
5 min

Total Time
1 hr



Ingredients

- 2¼ cups (550 mL) whole milk
- 1 cup (250 mL) heavy cream
- ½ cup (125 mL) sugar or flavored syrup (see cook's tips)

- 1 tbsp (15 mL) vanilla extract
- Optional: Crushed cookies, cereal, chopped nuts, sliced fruit, or extra flavored syrup for topping

Directions

1. Add all the ingredients to a large bowl with a spout. Whisk for 2–3 minutes, or until the sugar or syrup has completely dissolved.
2. Press the Power Button to turn on the **FreezyFun Ultimate Frozen Drink & Soft-Serve Maker**, select the **soft serve** setting, press , and pour the mixture into the tank.
3. Let the mixture churn until the machine reads, "End," about 45 minutes.
4. Dispense all the soft serve into bowls, cones, or cups. Top with your favorite toppings like crushed cookies, chopped nuts, or sliced fruit and sauces, if you'd like.

Cool Cook's Tips

Switch up the flavor of your soft serve by using chocolate, strawberry, or caramel syrup instead of sugar.

Warm up the flavored syrup in the microwave to make it easier to add to your soft serve.

Skip the vanilla extract if you're using flavored syrup.

While soft serve is typically best enjoyed after churning, you can freeze your soft serve into ice cream by stirring in 1 packet (3.4 oz./96 g) instant pudding in any flavor to your mixture before churning. Then, dispense the soft serve into a freezer-safe container and place it in the freezer for at least 4 hours before serving.

High-Protein Cheesecake Soft Serve

soft serve

Yield
8–10 servings

Prep Time
5 min

Total Time
1 hr



Ingredients

- 1½ cups (375 mL) full-fat cottage cheese (see cook's tips)
- 1¾ cups (425 mL) whole milk (see cook's tips)
- ½ cup (125 mL) sugar

- 1 tbsp (15 mL) vanilla extract
- Optional Toppings: Pie filling or crushed graham crackers

Directions

1. Place the cottage cheese, milk, sugar, and vanilla in a blender. Blend until completely smooth. *(Important Note: The blended mixture should resemble cream and be pourable, with no lumps.)*
2. Press the Power Button to turn on the **FreezyFun Ultimate Frozen Drink & Soft-Serve Maker**, select the **soft serve** setting, press , and pour the mixture into the tank.
3. Let the soft serve churn until the machine reads, "End," about 45 minutes.
4. Dispense all the soft serve into bowls, cones, or cups. Top with pie filling and crushed graham crackers, if you'd like.

Cool Cook's Tips

Always use full-fat cottage cheese and whole milk for the best results.

Getting the measurements right is key! The sugar-to-fat ratio is what helps it freeze perfectly. Measure the cottage cheese with a dry measuring cup.

U.S. nutrients per serving (about ½ cup/125 mL): Calories 200, Total Fat 13 g, Saturated Fat 8 g, Cholesterol 40 mg, Sodium 40 mg, Carbohydrate 17 g, Fiber 0 g, Sugars 17 g (includes 13 g added sugar), Protein 3 g

U.S. nutrients per serving (about ½ cup/125 mL): Calories 180, Total Fat 3 g, Saturated Fat 2 g, Cholesterol 15 mg, Sodium 150 mg, Carbohydrate 18 g, Fiber 0 g, Sugars 17 g (includes 13 g added sugar), Protein 6 g

Frozen Strawberry Lemonade

slushie

Yield
2–8 servings

Prep Time
5 min

Total Time
30 min–1 hr



| Ingredients | 2 Servings | 4 Servings | 8 Servings |
|----------------------|-----------------------------------|------------------------------------|---------------------------------|
| Lemonade | 1 cup (250 mL) and more as needed | 2 cups (500 mL) and more as needed | 4 cups (1 L) and more as needed |
| Strawberries, hulled | ½ cup (125 mL) | 1 cup (250 mL) | 2 cups (500 mL) |

Optional Toppings: Sliced strawberries or lemon wedges to garnish

Directions

- Place the lemonade and strawberries in a blender and process until smooth. Add more lemonade to meet the desired yield. *(Important Note: The blended mixture should be pourable, with no lumps.)*
- Press the Power Button to turn on the **FreezyFun Ultimate Frozen Drink & Soft-Serve Maker**, select the **slushie** setting, press **⏻** to start, and pour the mixture into the tank.
- Let the mixture churn until the machine reads, “End.”
- Dispense the frozen drink into cups and garnish with strawberries or a lemon wedge, if you'd like.

Cool Cook's Tips

In a rush? Smaller servings will slush faster than larger servings.
Customize the flavors by swapping the strawberries with your favorite fruit and lemonade for limeade.
Press the + Button to make a thicker slushie.

U.S. nutrients per serving (about 1 cup/250 mL): Calories 80, Total Fat 0 g, Saturated Fat 0 g, Cholesterol 0 mg, Sodium 10 mg, Carbohydrate 21 g, Fiber 1 g, Sugars 20 g (includes 18 g added sugar), Protein 0 g

Frozen Mai Tai

spiked slush

Yield
2–8 servings

Prep Time
5 min

Total Time
30 min–1 hr



| Ingredients | 2 Servings | 4 Servings | 8 Servings |
|-------------------------|-------------------|-------------------|--------------------|
| Light rum | 1 fl. oz. (30 mL) | 2 fl. oz. (60 mL) | 4 fl. oz. (125 mL) |
| Dark rum | 1 fl. oz. (30 mL) | 2 fl. oz. (60 mL) | 4 fl. oz. (125 mL) |
| Orange liquor | ½ fl. oz. (15 mL) | 1 fl. oz. (30 mL) | 2 fl. oz. (60 mL) |
| Almond extract | ¼ tsp (1 mL) | ½ tsp (2 mL) | ¾ tsp (4 mL) |
| Pineapple juice | ⅔ cup (150 mL) | 1½ cups (315 mL) | 2 cups (500 mL) |
| Orange juice | ⅓ cup (75 mL) | ⅔ cup (150 mL) | 1 cup (250 mL) |
| Limeade | ⅓ cup (75 mL) | ⅔ cup (150 mL) | 1 cup (250 mL) |
| Water | ⅓ cup (75 mL) | ⅔ cup (150 mL) | 1 cup (250 mL) |
| Maraschino cherry juice | 1 tbsp (15 mL) | 2 tbsp (30 mL) | 3 tbsp (45 mL) |

Optional Toppings: Maraschino cherries or lime wedges to garnish

Directions

- Add all the ingredients to a large bowl with a spout. Whisk until completely combined.
- Press the Power Button to turn on the **FreezyFun Ultimate Frozen Drink & Soft-Serve Maker**, select the **spiked slush** setting, press **⏻**, and pour the mixture into the tank.
- Let the mixture churn until the machine reads, “End.”
- Dispense the frozen drink into cups and garnish with maraschino cherries or a lime wedge, if you'd like.

Cool Cook's Tips

In a rush? Smaller servings will slush faster than larger servings.
If you only have one type of rum, just use more of the one you have on hand.
Press the + Button to make a thicker spiked slush.

U.S. nutrients per serving (about 1 cup/250 mL): Calories 180, Total Fat 0 g, Saturated Fat 0 g, Cholesterol 0 mg, Sodium 10 mg, Carbohydrate 22 g, Fiber 0 g, Sugars 20 g (includes 5 g added sugar), Protein 1 g

FreezyFun Milkshake

milkshake

Yield
2–8 servings

Prep Time
5 min

Total Time
30 min–1 hr



| Ingredients | 2 Servings | 4 Servings | 8 Servings |
|------------------------------------|------------------|----------------|----------------|
| Whole milk | 1½ cups (375 mL) | 3 cups (1 L) | 6 cups (1.4 L) |
| Heavy cream | ¼ cup (60 mL) | ½ cup (125 mL) | 1 cup (250 mL) |
| Granulated sugar or flavored syrup | ¼ cup (60 mL) | ½ cup (125 mL) | 1 cup (250 mL) |
| Vanilla extract | ½ tsp (7 mL) | 1 tsp (15 mL) | 2 tsp (30 mL) |

Optional: Whipped cream, sprinkles, or more syrup for drizzling

Directions

1. Add all the ingredients to a large bowl with a spout. Whisk for 2–3 minutes, or until the sugar or syrup has completely dissolved.
2. Press the Power Button to turn on the **FreezyFun Ultimate Frozen Drink & Soft-Serve Maker**, select the **milkshake** setting, press **⏻** to start, and pour the mixture into the tank.
3. Let the mixture churn until the machine reads, “End.”
4. Dispense the frozen drink into cups. Top with whipped cream, sprinkles, or flavored syrup, if you'd like.

Cool Cook's Tips

- In a rush? Smaller servings will slush faster than larger servings.
- Make it easier to add in the syrup by warming it up in the microwave for 30 seconds.
- For a protein boost, add 1 scoop (approximately 3 tsp/45 mL) of protein powder per serving to the base mixture before churning.
- Press the + Button to make a thicker milkshake.

U.S. nutrients per serving (about 1 cup/250 mL): Calories 320, Total Fat 17 g, Saturated Fat 10 g, Cholesterol 50 mg, Sodium 85 mg, Carbohydrate 35 g, Fiber 0 g, Sugars 35 g (includes 26 g added sugar), Protein 7 g

Caramel Frappé

frappe

Yield
2–8 servings

Prep Time
5 min

Total Time
30 min–1 hr



| Ingredients | 2 Servings | 4 Servings | 8 Servings |
|-----------------------------|----------------|------------------|------------------|
| Chilled coffee or cold brew | 1 cup (250 mL) | 2 cups (500 mL) | 4 cups (1 L) |
| Half & half | ¾ cup (150 mL) | 1½ cups (315 mL) | 2¾ cups (625 mL) |
| Caramel sauce | ¼ cup (60 mL) | ½ cup (125 mL) | 1 cup (250 mL) |

Optional Toppings: Whipped cream

Directions

1. Add all the ingredients to a large bowl with a spout. Whisk for 2–3 minutes, or until the caramel sauce is completely dissolved.
2. Press the Power Button to turn on the **FreezyFun Ultimate Frozen Drink & Soft-Serve Maker**, select the **frappe** setting, press **⏻** to start, and pour the mixture into the tank.
3. Let the mixture churn until the machine reads, “End.”
4. Dispense the frozen drink into cups and top with whipped cream, if you'd like.

Cool Cook's Tips

- In a rush? Smaller servings will slush faster than larger servings.
- Use a different flavored syrup to switch up the taste.
- Make it easier to add in the syrup by warming it up in the microwave for 30 seconds.
- For a protein boost, add 1 scoop (approximately 3 tsp/45 mL) of protein powder per serving to the base mixture before churning.
- Swap the half & half with plant-based milk and dairy-free coffee creamer to make a dairy-free frappe.
- Press the + Button to make a thicker frappe.

U.S. nutrients per serving (about 1 cup/250 mL): Calories 220, Total Fat 8 g, Saturated Fat 5 g, Cholesterol 40 mg, Sodium 100 mg, Carbohydrate 30 g, Fiber 0 g, Sugars 20 g (includes 17 g added sugar), Protein 3 g

Blueberry Frozen Yogurt

soft serve

Yield
8 servings

Prep Time
10 min

Total Time
1 hr



Ingredients

- 1¼ cups (300 mL) whole milk
- 1½ cups (375 mL) full-fat Greek yogurt
- 1 cup (250 mL) blueberries (see cook's tips)
- ¼ cup (60 mL) sugar

Optional: Fresh fruit, sprinkles, crushed cookies, or candies for topping

Directions

1. Add all the ingredients to the **Deluxe Cooking Blender** and blend until smooth on **(SMOOTHIE)**. *(Important Note: The blended mixture should resemble cream and be pourable, with no lumps.)*
2. Press the Power Button to turn on the **FreezyFun Ultimate Frozen Drink & Soft-Serve Maker**, select the **(soft serve)** setting, press **(⏻)** to start, and pour the mixture into the tank.
3. Let the mixture churn until the machine reads, "End."
4. Dispense all the soft serve into bowls, cones, or cups. Top with fresh fruit, sprinkles, crushed cookies, or candies, if you'd like.

Cool Cook's Tip

Change up the color and flavor of your soft serve by swapping the blueberries for your favorite fruit.

U.S. nutrients per serving: Calories 100, Total Fat 3.5 g, Saturated Fat 2 g, Cholesterol 10 mg, Sodium 30 mg, Carbohydrate 12 g, Fiber 0 g, Sugars 11 g (includes 6 g added sugar), Protein 5 g

Orange Sherbet

soft serve

Yield
8 servings

Prep Time
5 min

Total Time
1 hr



Ingredients

- 2 cups (500 mL) orange juice
- ¾ cup (175 mL) sugar
- ½ cup (125 mL) heavy cream
- ½ cup (125 mL) whole milk

Directions

1. Add all the ingredients to a large bowl with a spout. Whisk for 2–3 minutes, or until the sugar is completely dissolved.
2. Press the Power Button to turn on the **FreezyFun Ultimate Frozen Drink & Soft-Serve Maker**, select the **(soft serve)** setting, press **(⏻)** to start, and pour the mixture into the tank.
3. Let the mixture churn until the machine reads, "End."
4. Dispense all the sherbet into bowls, cones, or cups.

Cool Cook's Tip

Switch up the flavor by using lemonade, limeade, or your favorite fruit juice instead of orange juice.

U.S. nutrients per serving: Calories 160, Total Fat 6 g, Saturated Fat 4 g, Cholesterol 20 mg, Sodium 15 mg, Carbohydrate 27 g, Fiber 0 g, Sugars 25 g (includes 19 g added sugar), Protein 1 g

Soft-Serve Custard

soft serve

Yield
8–10 servings

Prep Time
10 min

Total Time
3 hr



Ingredients

- | | |
|----------------------------|--------------------------------|
| 2 cups (500 mL) whole milk | 6 egg yolks |
| 1 cup (250 mL) heavy cream | 1 tbsp (15 mL) vanilla extract |
| ½ cup (125 mL) sugar | |

Directions

1. Combine the milk, heavy cream, and sugar in a small saucepan. Bring to a gentle boil over medium heat. Remove from the heat.
2. Whisk the egg yolks in a medium bowl. Slowly add 1 cup (250 mL) of the hot cream mixture to the egg yolks to temper the eggs. Then, slowly add it back into the hot cream mixture.
3. Cook over medium-low heat, stirring occasionally for 5 minutes, or until the mixture thickens enough to coat the back of a spoon and reaches 165°F (75°C).
4. Remove the saucepan from the heat. Add the vanilla extract and pour the mixture into a clean bowl. Cover and let the bowl chill in the refrigerator for about 2 hours, or until it's cool.
5. Press the Power Button to turn on the **FreezyFun Ultimate Frozen Drink & Soft-Serve Maker**, select the **soft serve** setting, press , and pour the mixture into the tank.
6. Let the mixture churn until the machine reads, "End."
7. Dispense all the soft serve into bowls, cones, or cups. Add your favorite toppings or sauces, if you'd like.

U.S. nutrients per serving: Calories 230, Total Fat 16 g, Saturated Fat 9 g, Cholesterol 180 mg, Sodium 40 mg, Carbohydrate 17 g, Fiber 0 g, Sugars 17 g (includes 13 g added sugar), Protein 5 g

Vegan Soft Serve

soft serve

Yield
8 servings

Prep Time
10 min

Total Time
1 hr



Ingredients

- | | |
|--|--------------------------------|
| ¾ cup (175 mL) cashews (see cook's tip) | ½ cup (125 mL) sugar |
| 1 can (13.6 oz./400 mL) full-fat, unsweetened coconut milk | 1 tbsp (15 mL) vanilla extract |
| 1 cup (250 mL) unsweetened almond or oat milk | |

Directions

1. Add the cashews and water to a bowl. Cover and microwave it for 5 minutes. Drain and discard the liquid.
2. Add the rest of the ingredients to the **Deluxe Cooking Blender**. Add the cashews, set the blender to **GRIND**, and press the wheel to start. *(Important Note: The blended mixture should be pourable, with no lumps.)*
3. Press the Power Button to turn on the **FreezyFun Ultimate Frozen Drink & Soft-Serve Maker**, select the **soft serve** setting, press , and pour the mixture into the tank.
4. Let the mixture churn until the machine reads, "End."
5. Dispense all the soft serve into bowls, cones, or cups. Add your favorite toppings or sauces, if you'd like.

Cool Cook's Tip

To soften the cashews, you can either microwave them or let them soak in cool water for 3–5 hours.

U.S. nutrients per serving: Calories 210, Total Fat 15 g, Saturated Fat 10 g, Cholesterol 0 mg, Sodium 30 mg, Carbohydrate 18 g, Fiber 0 g, Sugars 14 g (includes 13 g added sugar), Protein 3 g



Using the Wash Preset

This cycle agitates, without cooling, to rinse the tank.

1. Dispense any remaining frozen drink.
2. Stop your preset by pressing the **X** button.
3. As the appliance automatically switches to the Wash preset, fill the tank with water up to the maximum fill line. Press the **W** button.
4. When the machine reads, "End," place a large bowl under the spout and dispense slowly.

TIP: Use the Soft-Serve Tip for better control of the water flow.

5. After the preset ends, repeat the process or place the tank in the dishwasher if it looks murky.

Share Your Creations



Learn more about the FreezyFun Ultimate Frozen Drink & Soft-Serve Maker.

pamperedchef.com
pamperedchef.ca

One Pampered Chef Lane | Addison, Illinois 60101-5630 USA
© 2026 Pampered Chef used under license. Pampered Chef, Pampered Chef and Spoon design, PC and Spoon design, and Spoon design are trademarks used under license.
P44486-04/26